

LONGITUDINAL SECTION

SCALE: 3/8" = 1'-0"

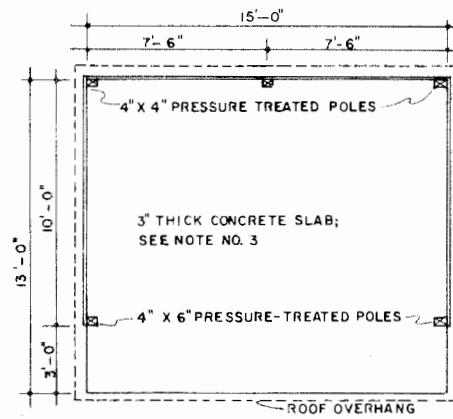

PLAN

SCALE: 1/4" = 1'-0"

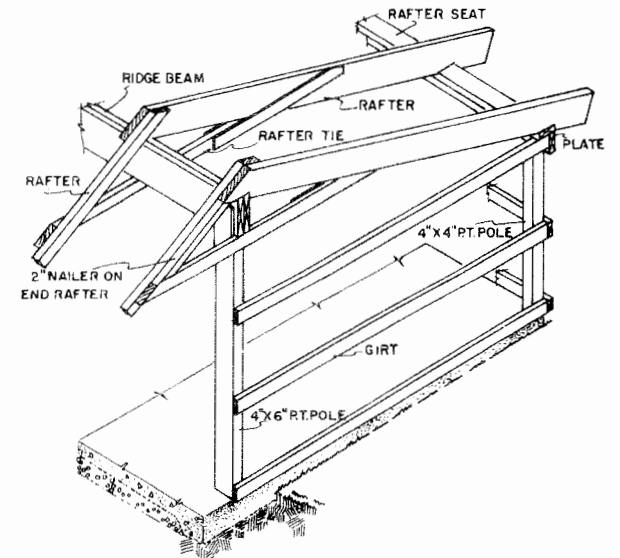

FRAMING PERSPECTIVE

NO SCALE

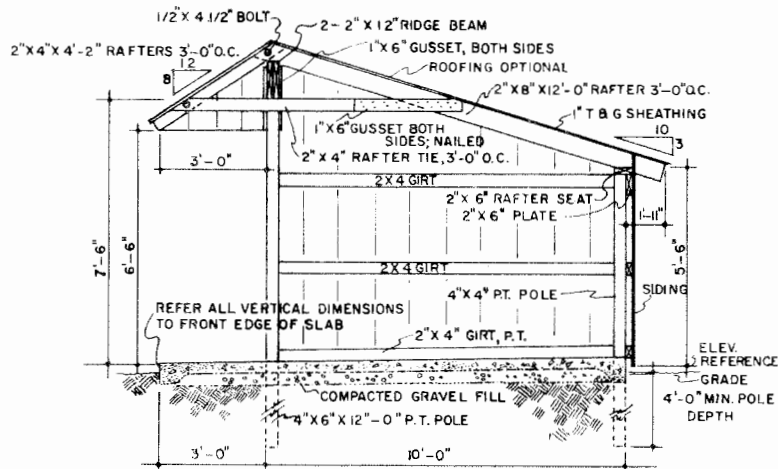

CROSS SECTION

SCALE: 3/8" = 1'-0"

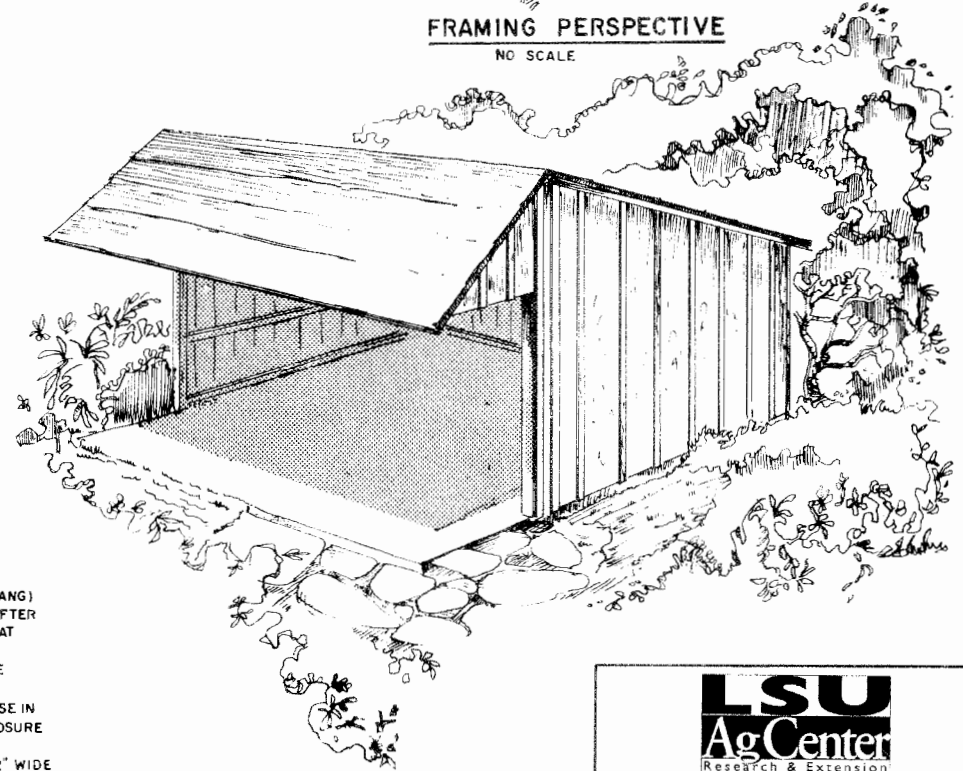

- DESIGN IS BASED ON ROUGH SAWN EASTERN HEMLOCK.
- DESIGN ROOF LOAD: 30lbs. PER SQ. FOOT.
- CONCRETE FLOOR SLAB HAS THICKENED EDGE 9" DEEP BY 6" WIDE ALONG BOTTOM SURFACE; SLOPE FLOOR APPROX. 1/4" PER FOOT FROM REAR TO OPEN FRONT FOR DRAINAGE (PUDDLING WITHIN SHELTER FROM WIND DRIVEN RAIN MAY BE MINIMIZED BY INCREASING THE SLOPE OF THE 3' FRONT APRON). REQUEST A CONCRETE MIX WITH 3/4" MAX. SIZE AGGREGATE, 6 1/2 SACKS OF CEMENT PER CUBIC YARD, 6GAL WATER / CEMENT RATIO, AND 6PERCENT ENTRAINED AIR BY VOLUME.
- TAMPED EARTH OR GRAVEL FLOORS MAY BE SUBSTITUTED FOR CONCRETE IF DESIRED.
- ALL WOOD IN CONTACT WITH EARTH OR CONCRETE SHOULD BE PRESSURE TREATED WITH A PRESERVATIVE.
- ASSEMBLE RAFTER UNITS ON THE GROUND IN A JIG FOR BOLT LOCATION; DETACH SHORT 2 X 4 (OVERHANG) RAFTER FROM THE UNIT FOR ERECTION; THE 2 X 8 RAFTER SHOULD BE ON THE OUTSIDE OF THE 2 X 4 OVERHANG AT BOTH ENDS OF THE BUILDING.
- ERECT THE 4 X 6 POLES WITH RIDGE-BEAM FIRST; THE REAR WALL POLES CAN THEN BE LOCATED.
- FOR WEATHER PROTECTION OR SECURE STORAGE, CLOSE IN THE FRONT. WITH AN OPEN FRONT, A SOUTHERN EXPOSURE IS DESIREABLE.
- ROUGH-SAWN BOARD & BATTEN SIDING WITH 10" TO 12" WIDE BOARDS & 2" TO 3" WIDE BATTENS ON CRACKS BETWEEN BOARDS IS ATTRACTIVE. OTHER SIDING MATERIALS CAN BE USED IF DESIRED.



ADIRONDACK-TYPE SHELTER

MASS '66 EX. 5998 SHEET 1 OF 1

Disclaimer

This site makes available conceptual plans that can be helpful in developing building layouts and selecting equipment for various agricultural applications. These plans do not necessarily represent the most current technology or construction codes. They are not construction plans and do not replace the need for competent design assistance in developing safe, legal and well-functioning agricultural building system. The LSU Agriculture Center, the Mid-West Plan Service, the United States Department of Agriculture and none of the cooperating land-grant universities warranty these plans.